

Stac: 0+012,00

RO-ak-1

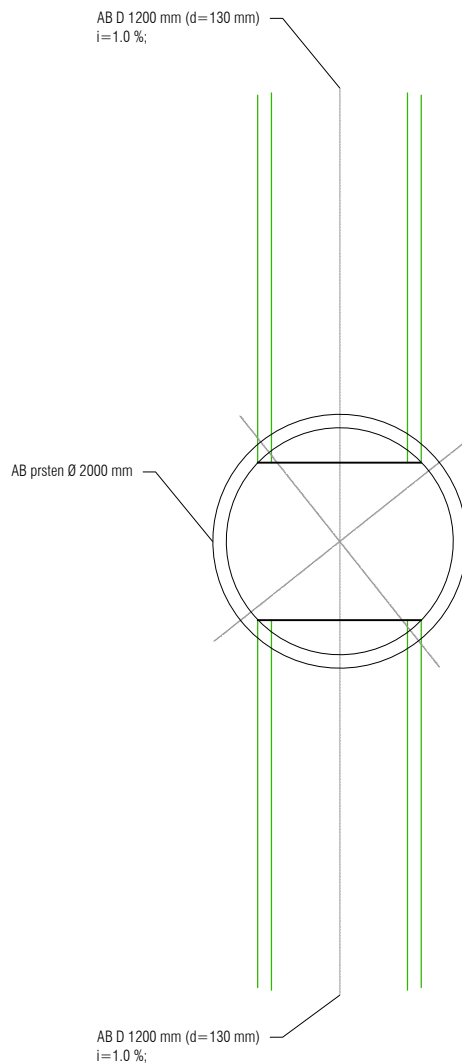

RO-ak-1

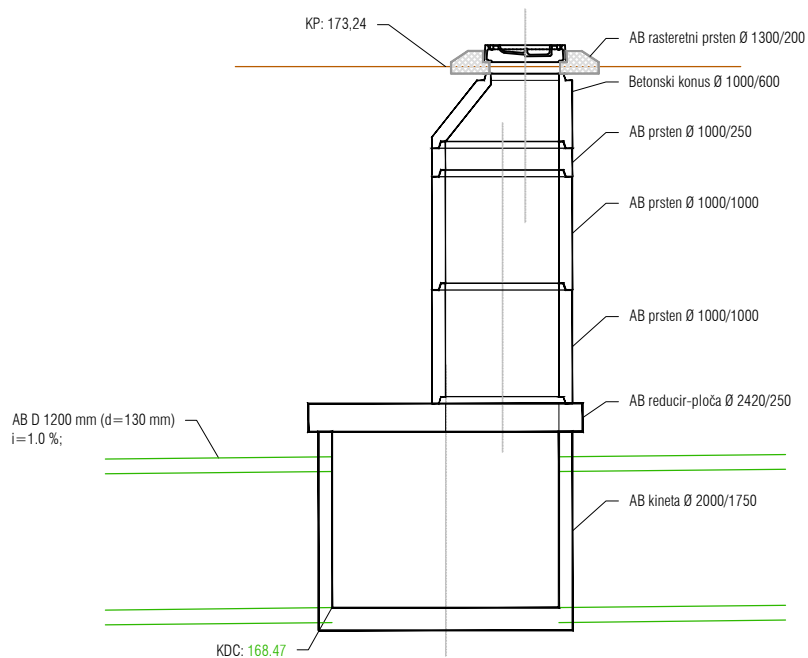

Stac: 0+077,50
RO-ak-2

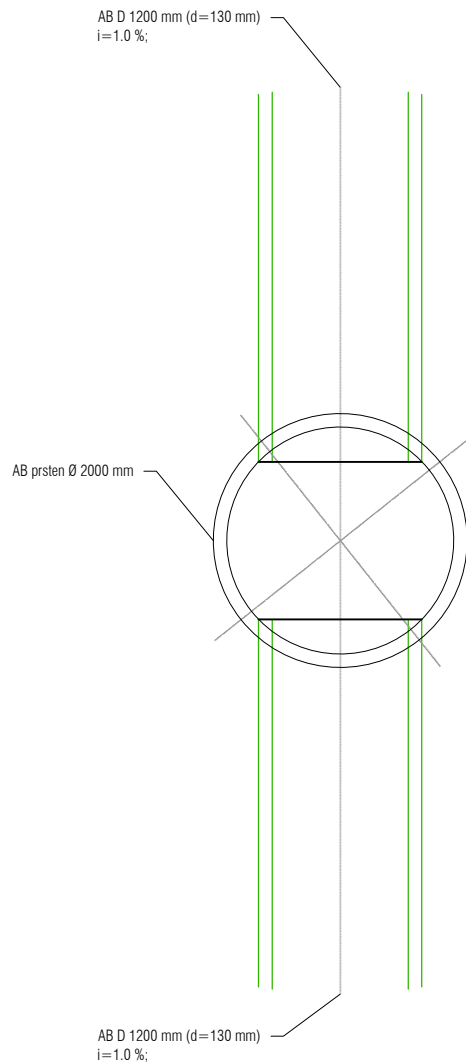

RO-ak-2

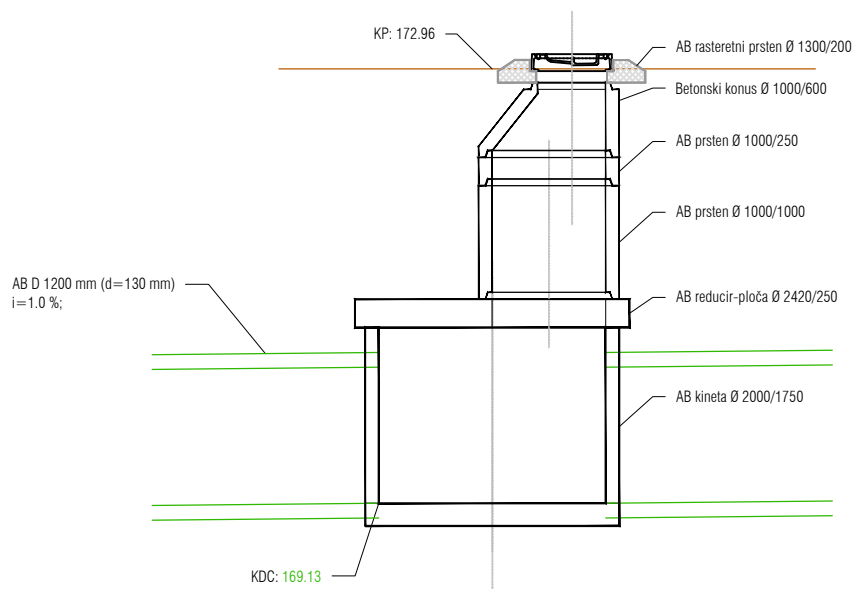

Stac: 0+143.00

RO-ak-3

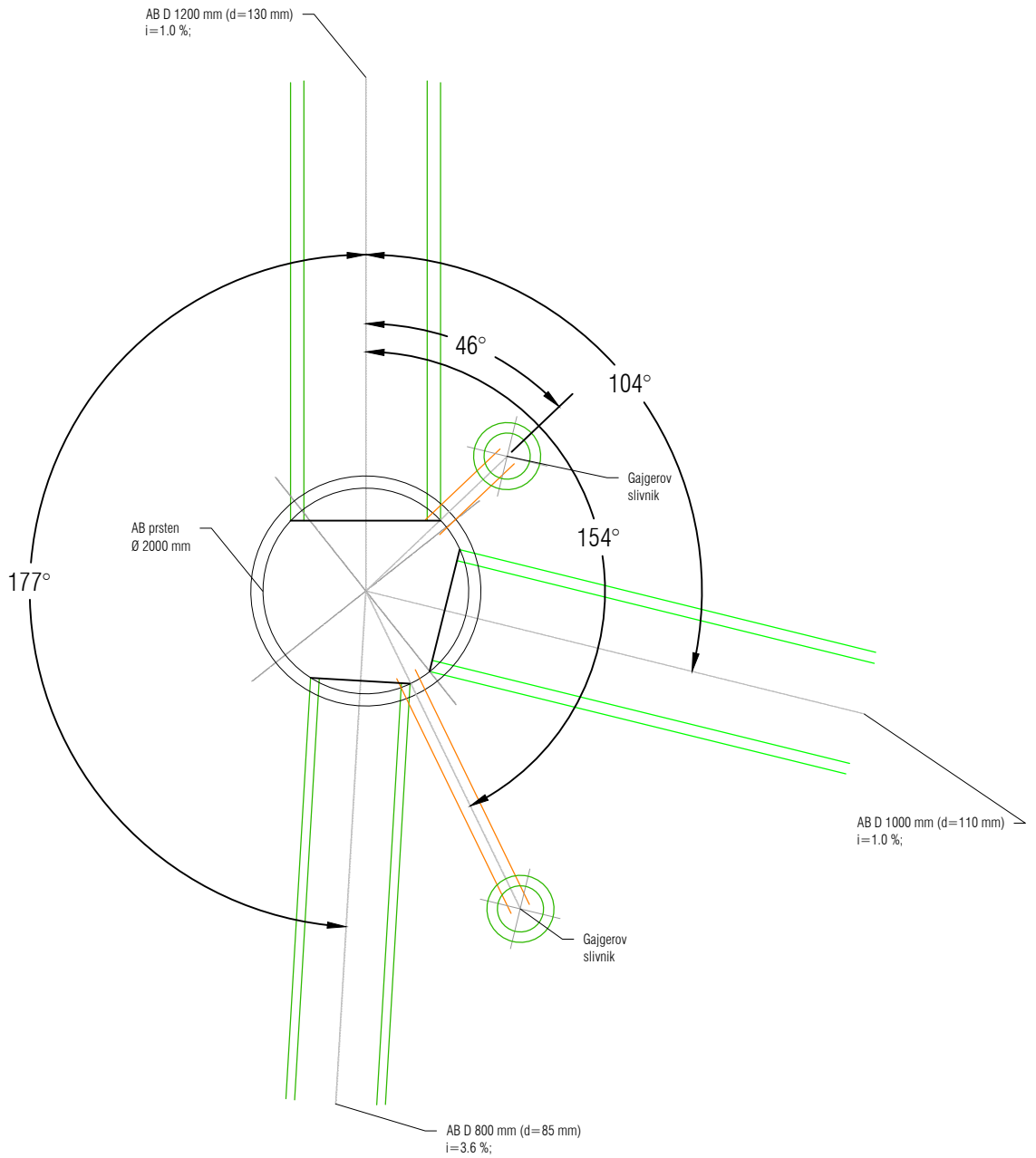

RO-ak-3

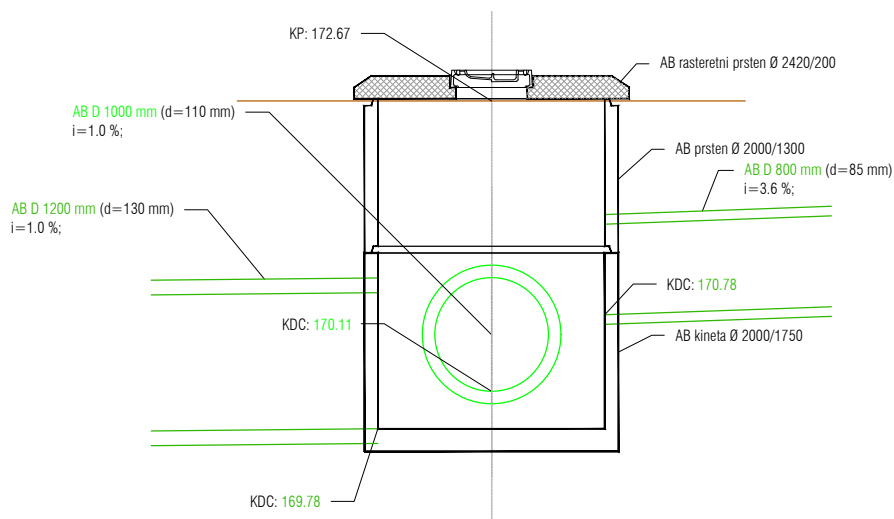

Stac: 0+167.10

RO-ak-4

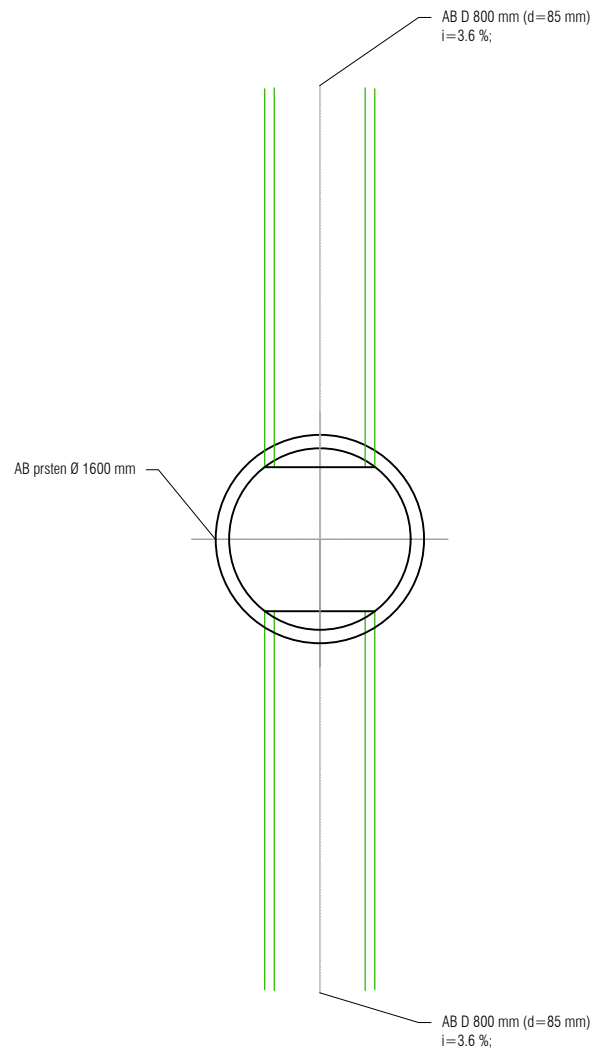

RO-ak-4

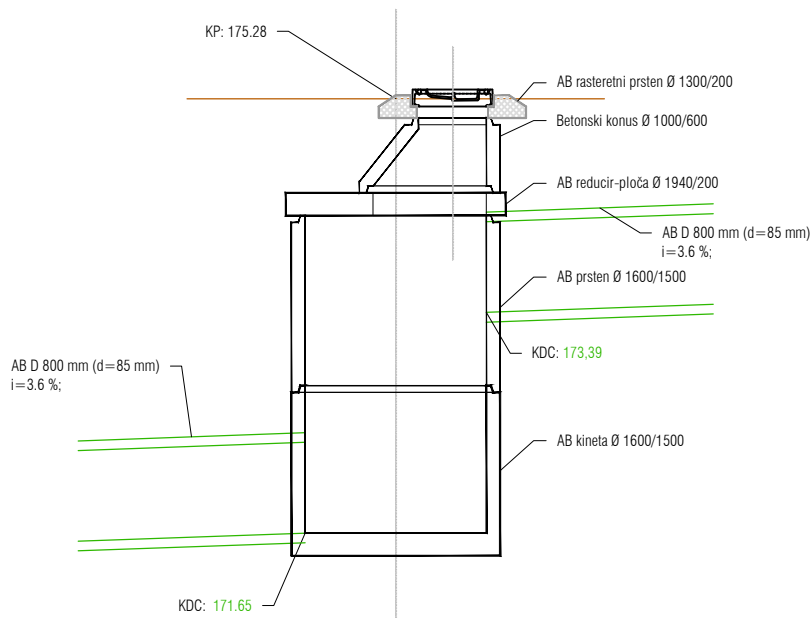

Stac: 0+197.60

RO-ak-5

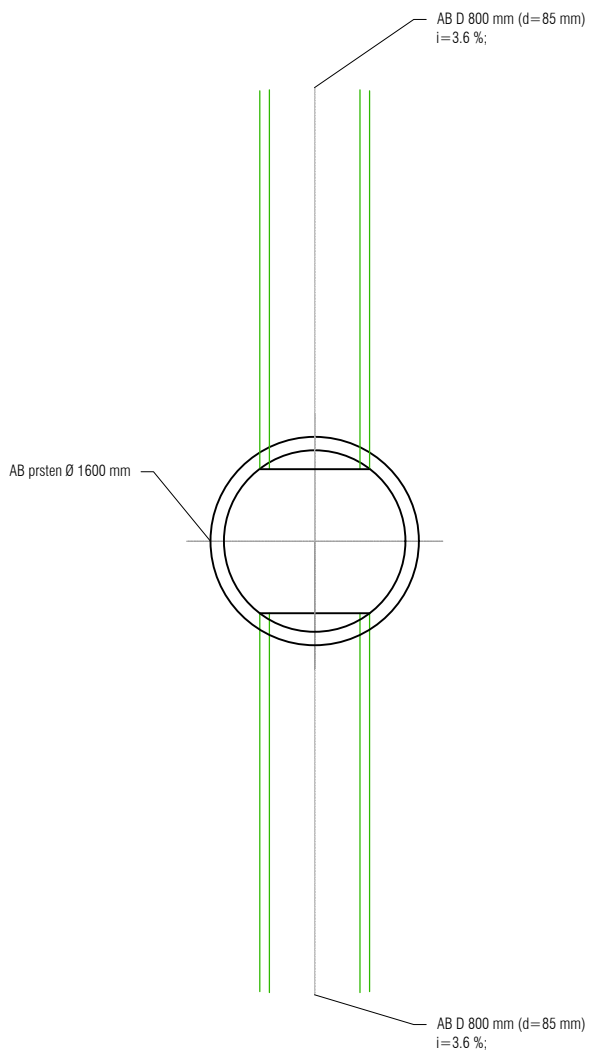

RO-ak-5

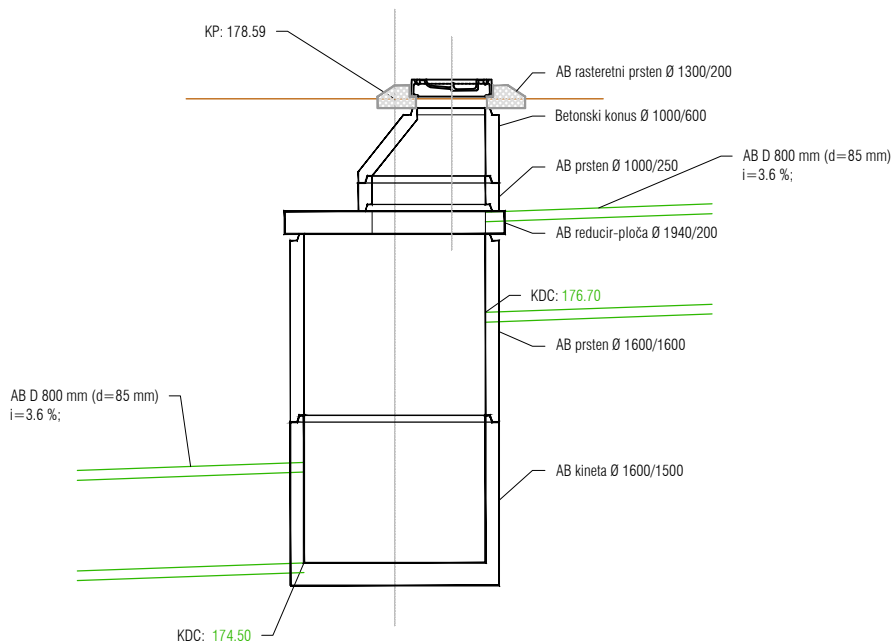

Stac: 0+220.00

RO-ak-6

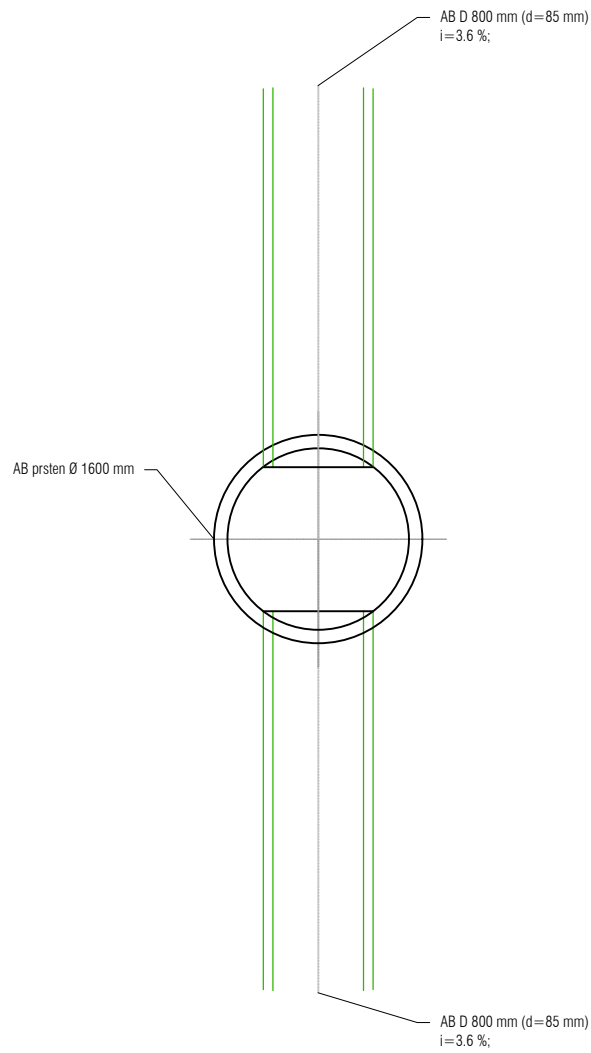

RO-ak-6

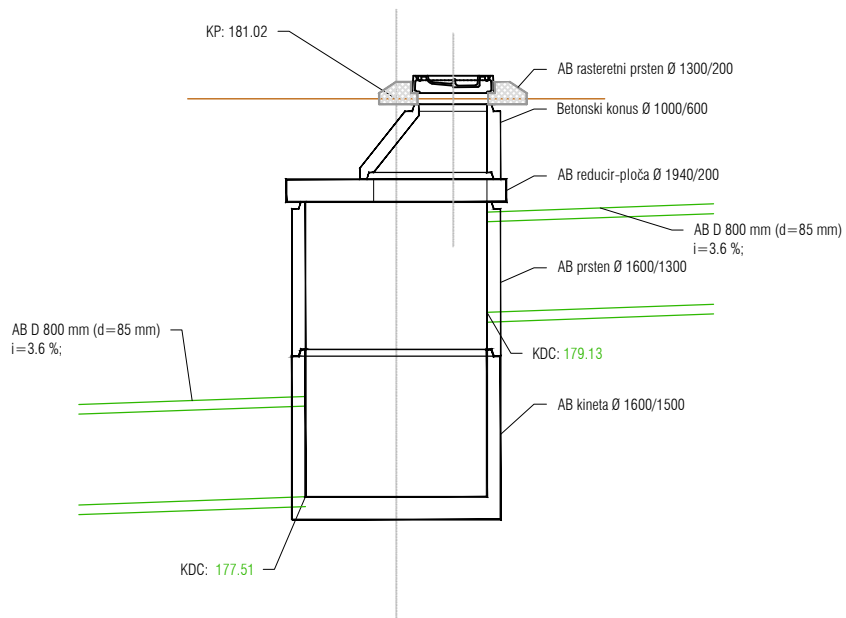

Stac: 0+258.50

RO-ak-7

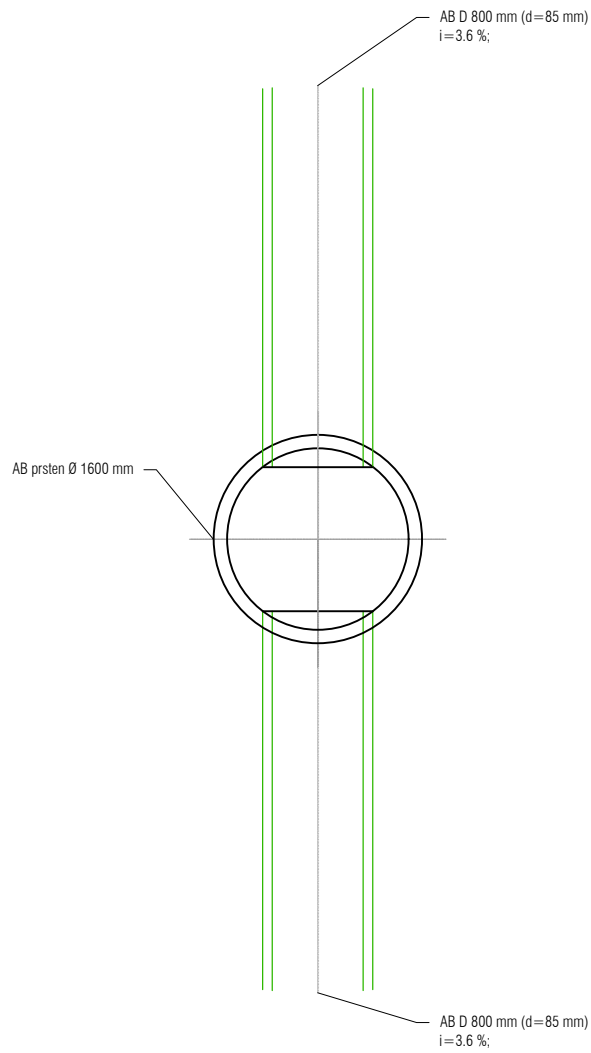

RO-ak-7

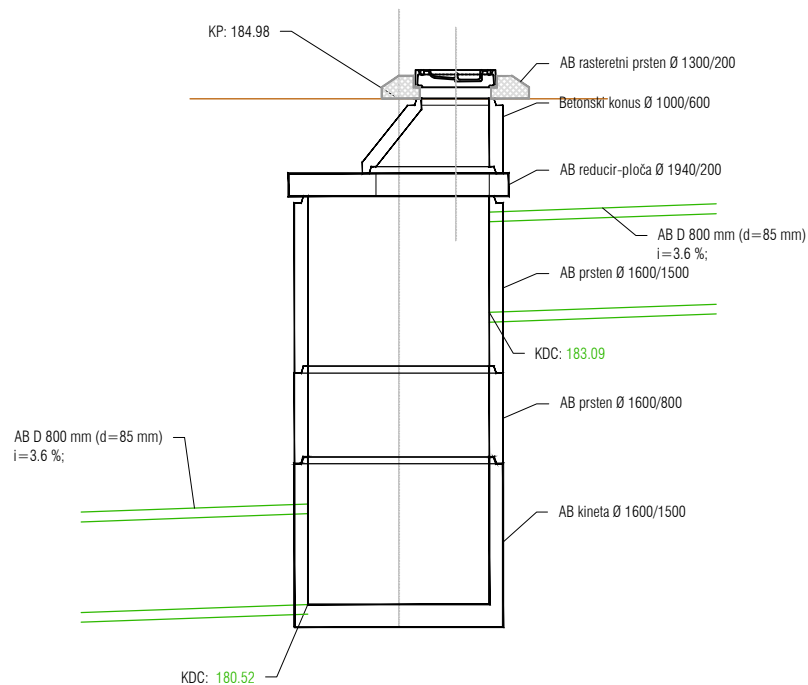

Stac: 0+297.00

RO-ak-8

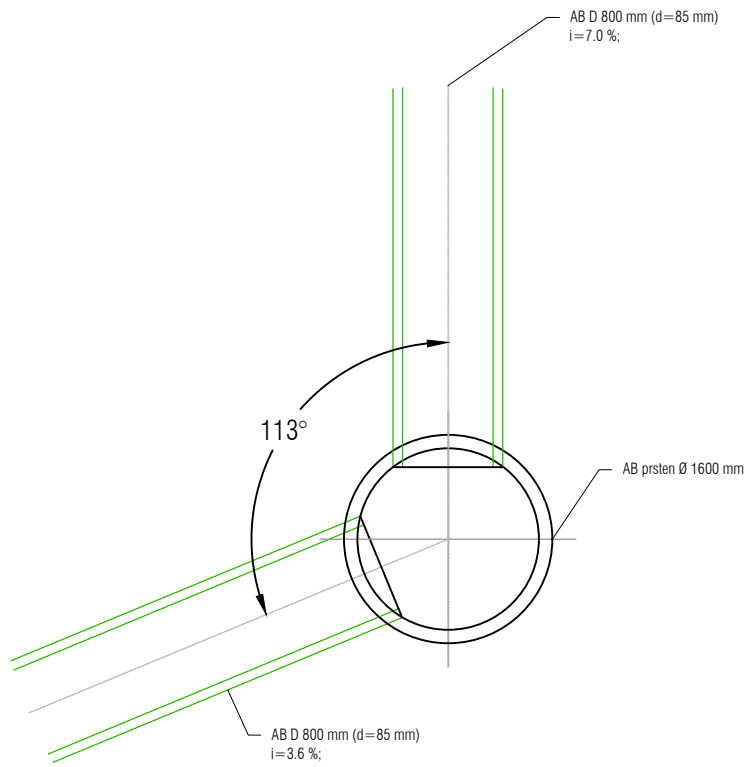

RO-ak-8

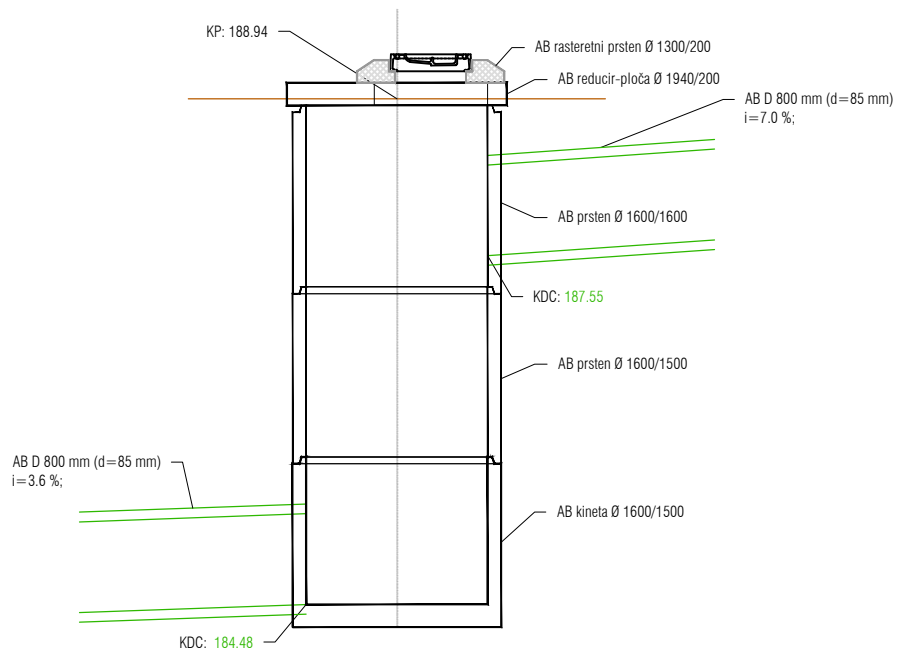

Stac: 0 + 306.60

RO-ak-8'

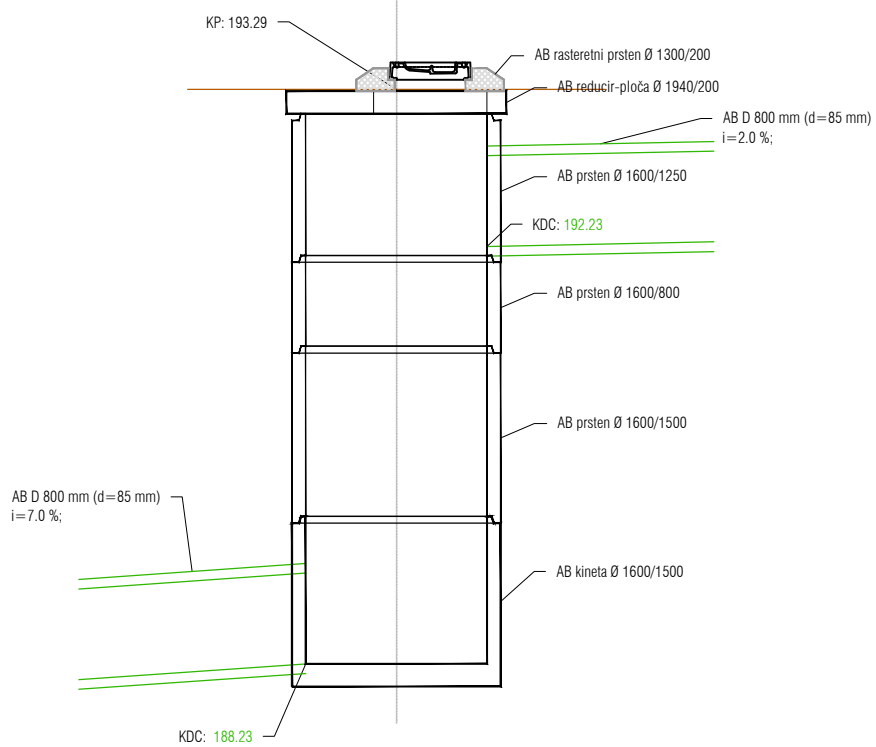
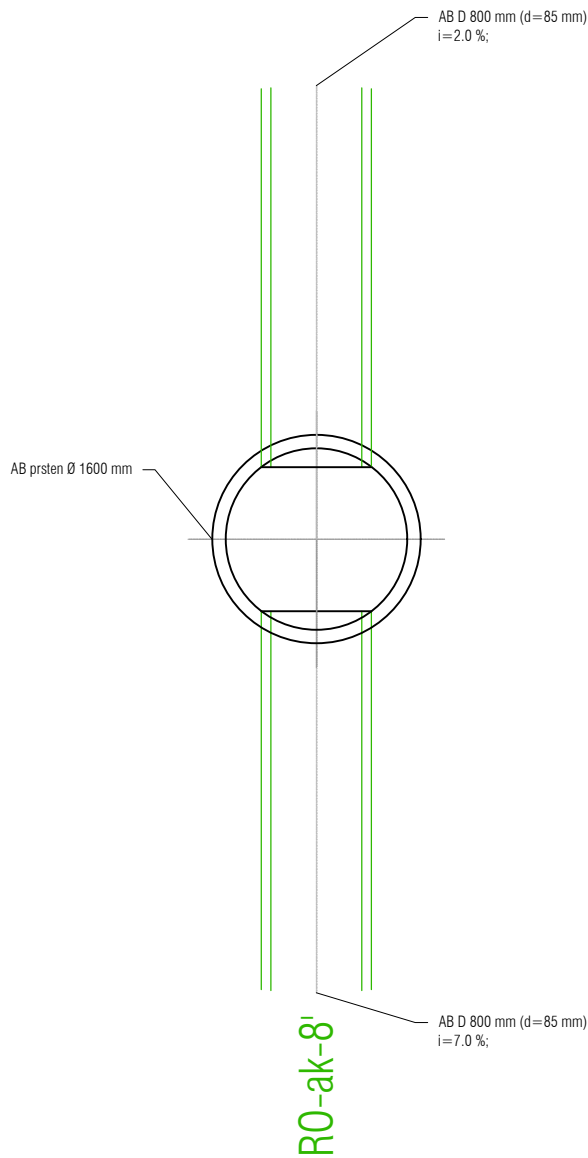

Stac: 0+316.15

RO-ak-9

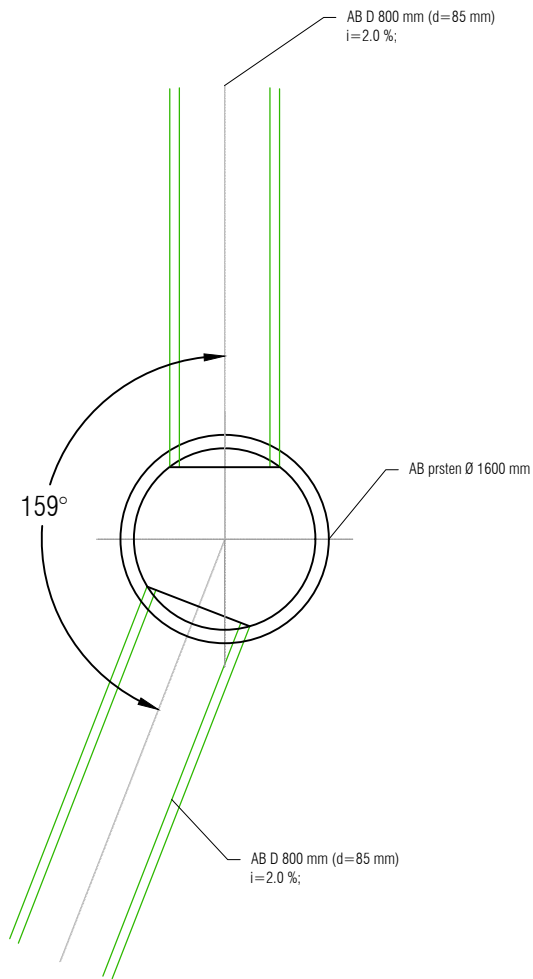

RO-ak-9

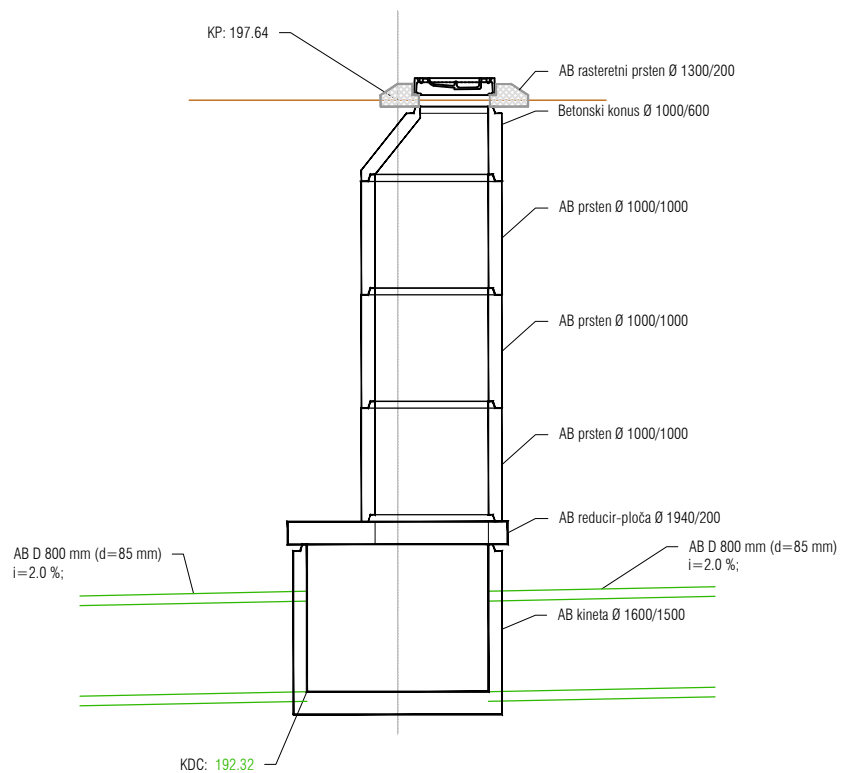

Stac: 0 + 363.65

RO-ak-10

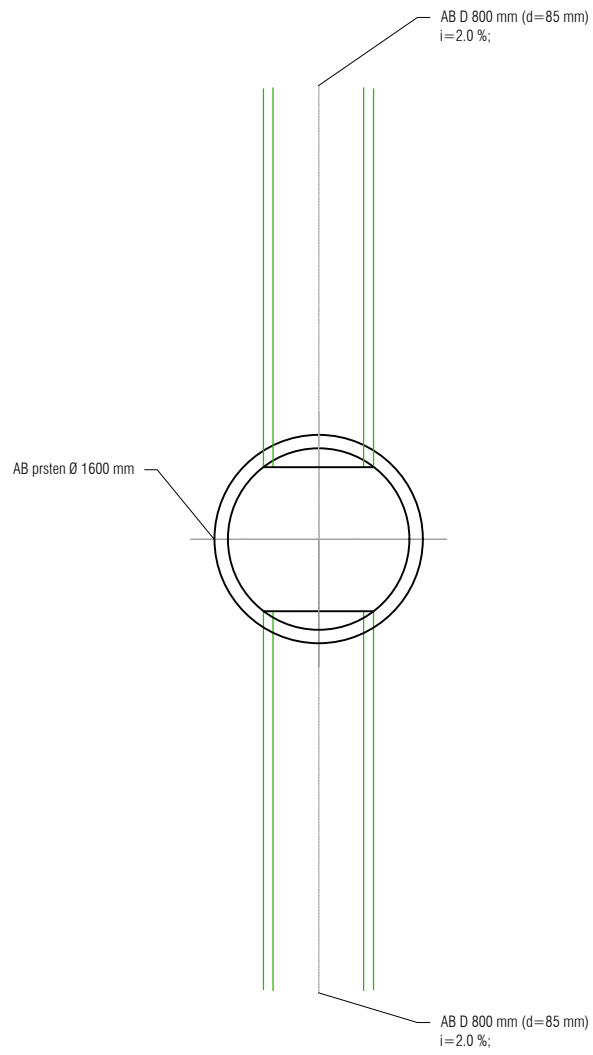

RO-ak-10

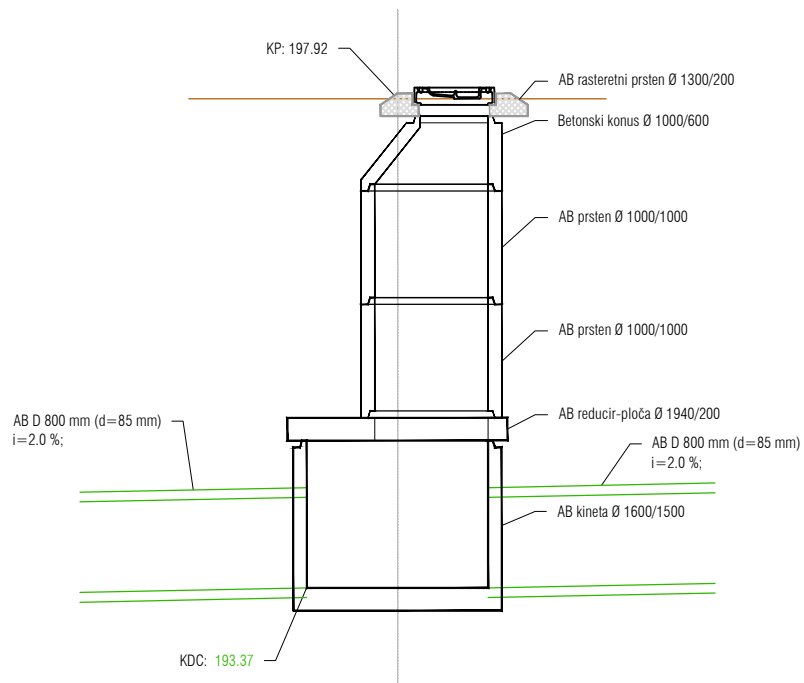

Stac: 0+411.15

RO-ak-11

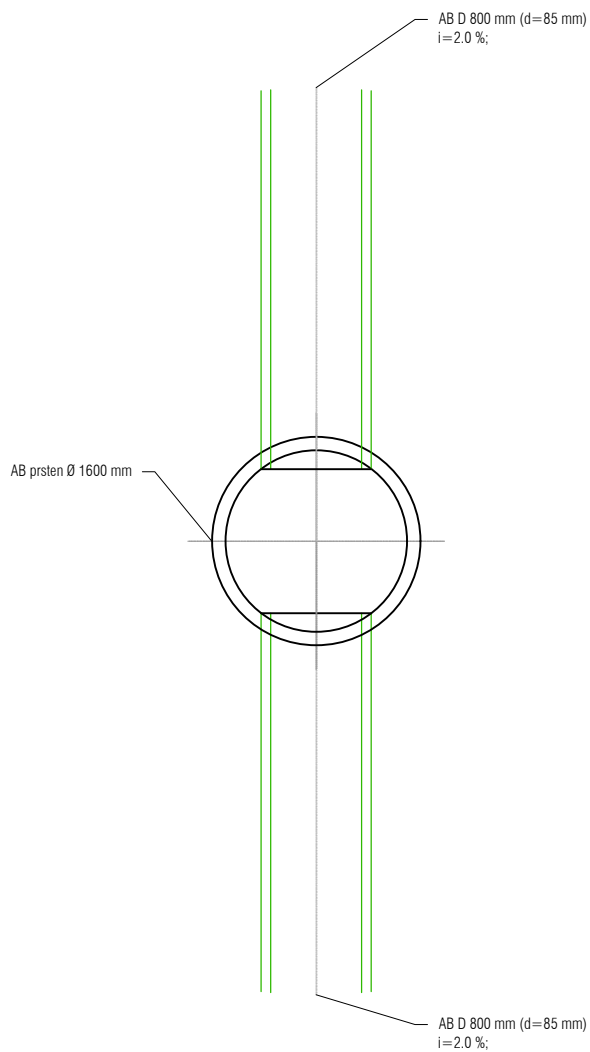

RO-ak-11

